

DWG. NO.  
DH0589

DESCRIPTION  
STIHL 3/8" pitch double end 14mm bar idler assembly

CREATED:  
06/16/17

UPDATED:  
09/19/17

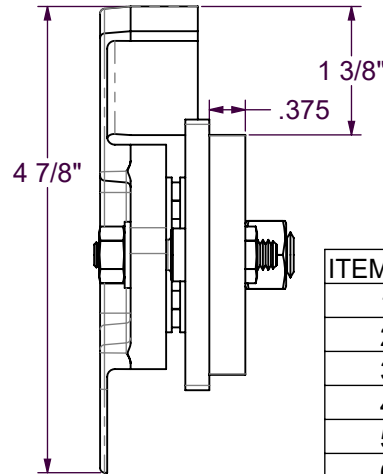
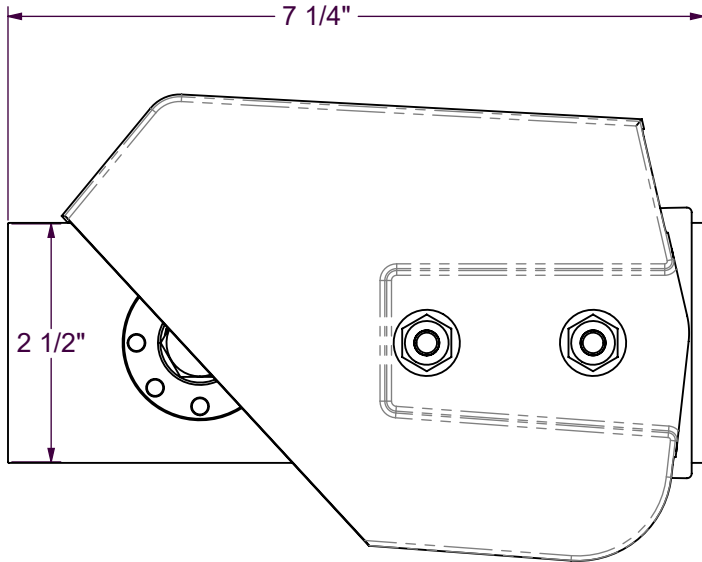
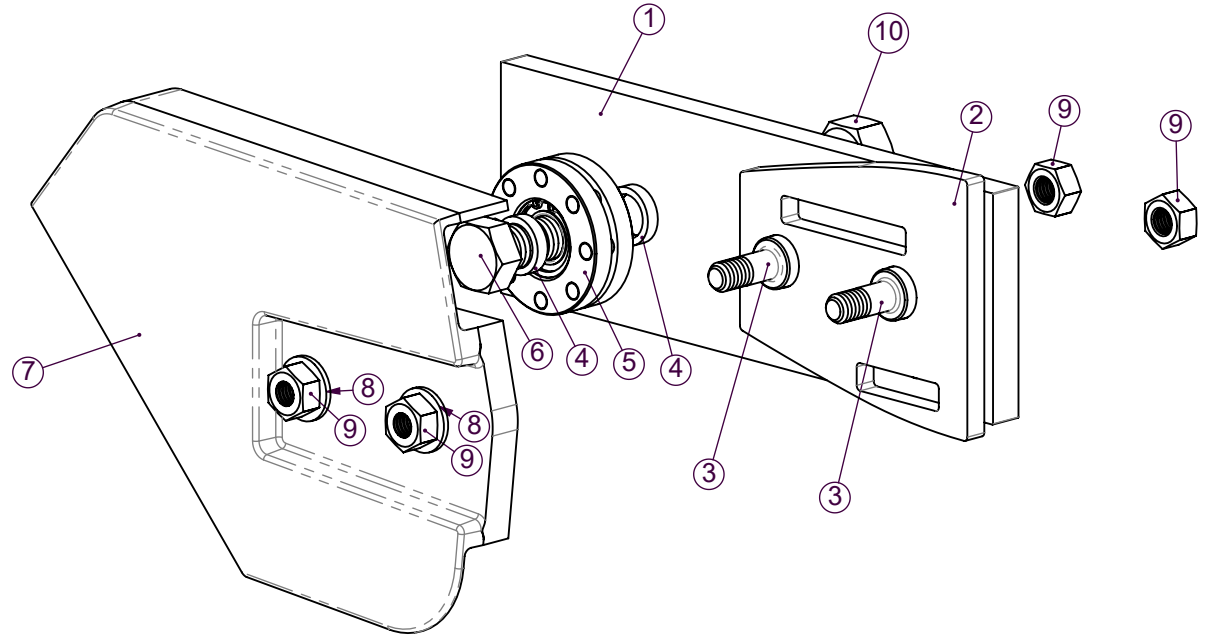

ITEM NO.	QTY.	PART NO.	DESCRIPTION
1	1	DH0587	DE BAR PLATE
2	1	DH0551	LARGE STIHL BAR SPACER
3	2	DH0552	14 mm BAR STUD
4	2	DH0588	BEARING SPACER
5	1	DS0005	3/8 X 9T Idler Sprocket Assembly
6	1	M1040C	M12-1.75 X 40 GRD. 10.9 CAP SCREW
7	1	DH0550	CHAIN BRAKE COVER, 537033501
8	2	FWZ10H	5/16 HT WASHER
9	4	FMN08CP	M8 X 1.25 NUT
10	1	FMN12CP	M12 X 1.75 NUT

NOTES & INFORMATION

APPROVALS

DRAWN	ED
CHECKED	
WEIGHT:	3.326 lbs.

THE INFORMATION CONTAINED IN THIS DRAWING IS THE SOLE PROPERTY OF 6K Products. REPRODUCTION IN PART OR WHOLE WITHOUT WRITTEN PERMISSION OF Ed Danzer IS PROHIBITED.

DO NOT SCALE DRAWING

UNLESS OTHERWISE SPECIFIED:  
DIMENSIONS ARE IN INCHES.  
TOLERANCES ARE:  
ANGLES FRACTIONS DECIMAL  
± .5° ± 1/16 X ± .032  
XX ± .015  
XXX ± .002

Sheet 1 of 1

**6K Products**

1006 143rd AVE. S.E.  
TENINO, WA 98589  
PHONE: (360) 264-7570  
FAX: (360) 264-5105