

6KProducts

Bringing reliability to high pressure hydraulic systems

DP0063

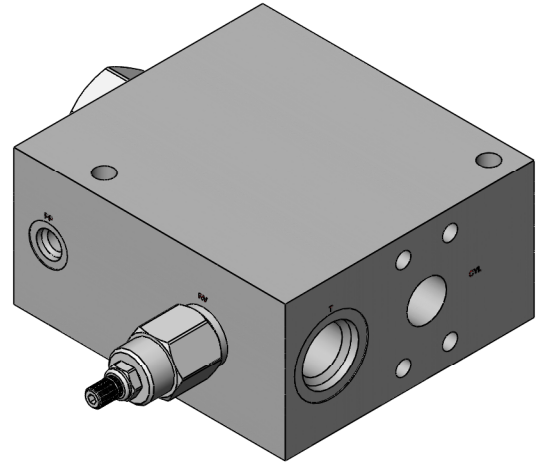
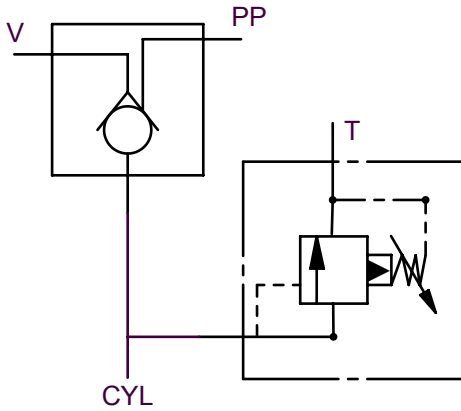

This assembly is designed to lock a cylinder in one direction with an overload relief. The PP port must be T connected to the cylinder other direction port to operate. The pressure is preset when ordered and can be field adjustable. For more information call 360-264-2141.

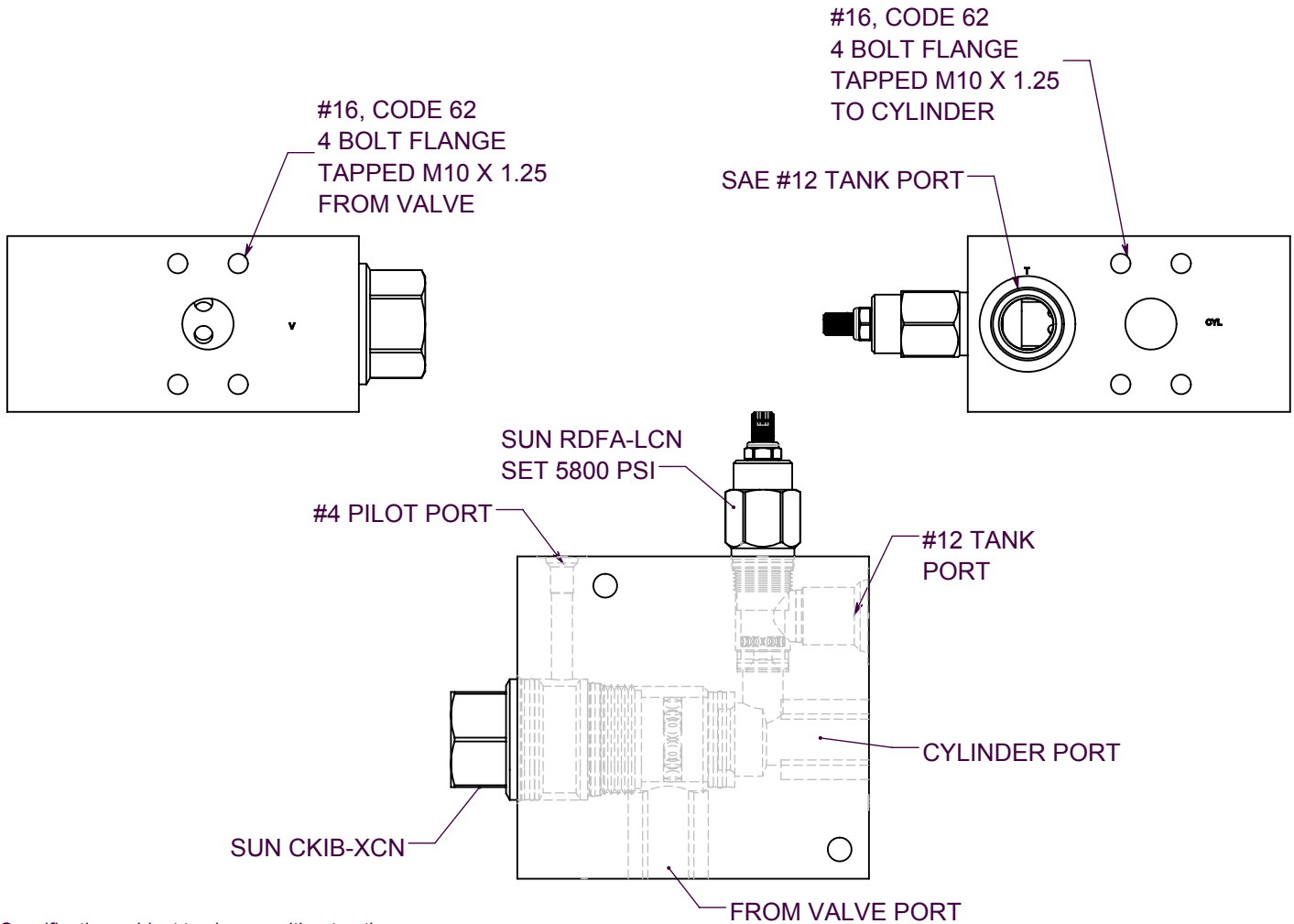

Specification subject to change without notice.