

6KProducts

Bringing reliability to high pressure hydraulic systems

DP0078

One Direction T-17A Load Holding Body Subassembly, #8 ORB Side and End Ported

Counterbalance Valve Symbol

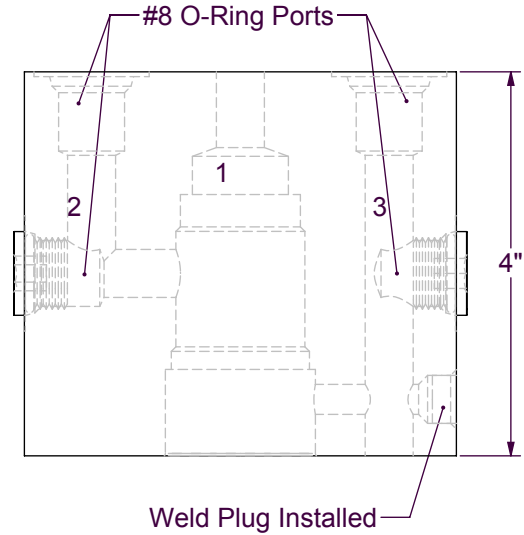
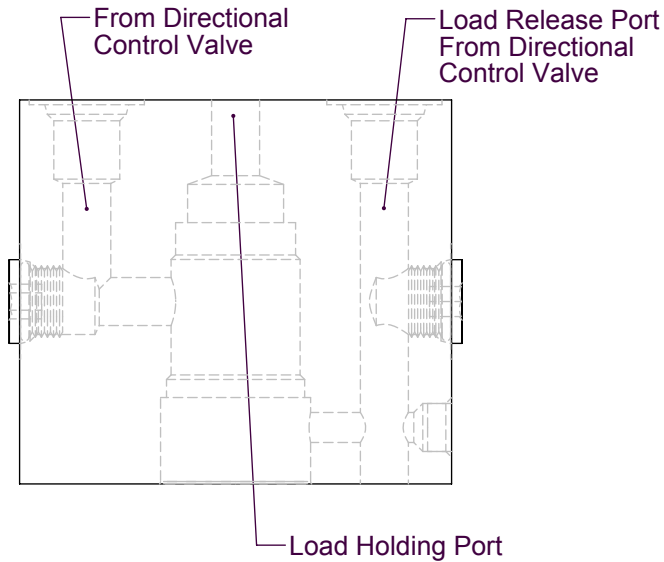
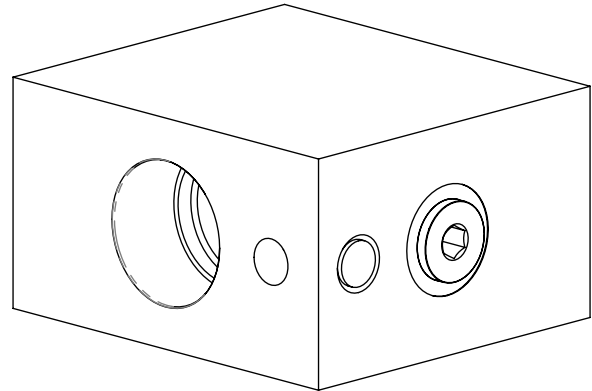
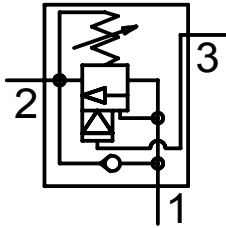

Pilot Operated Check Valve Symbol

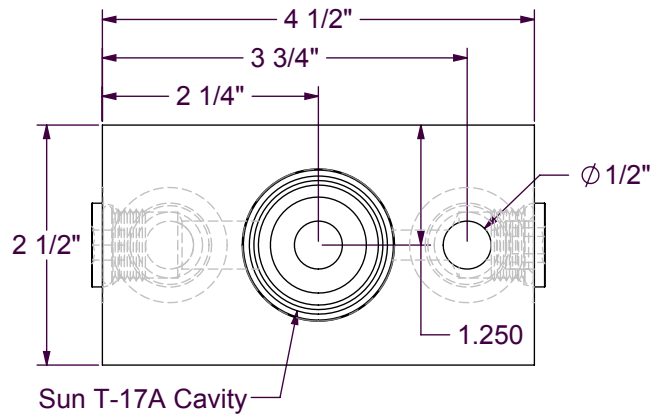
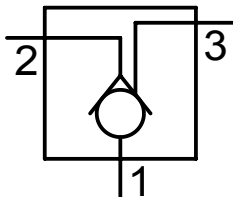

This manifold is made from cold drawn C1018 flat bar and is designed to be welded to Schedule 80 seamless pipe or DOM tubing. For best welding results, fit tubes, tack into location, preheat to 150°-200°F and weld with E80SD2 wire. Welding can be done with E70 filler material if E80 is not available.