

DP0082 50 GPM 3000 PSI DOUBLE DIVERTER

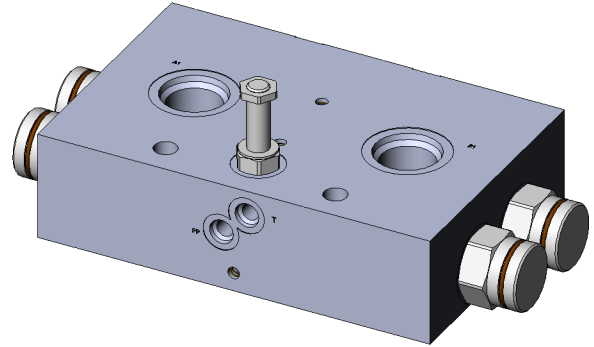

50 GPM, 3,000 PSI 6 PORT 2 POSITION SOLENOID CONTROLLED PILOT OPERATED DIVERTER VALVE ASSEMBLY WITH #12 O-RING FUNCTION PORTS AND #6 O-RING PILOT PORTS. In the neutral position, no pilot pressure, oil will flow bi-directionally from the from A1 and B1 ports to the A2 and B2 ports with the A3 and B3 ports blocked. When piloted, oil will flow bi-directionally from the from A1 and B1 ports to the A3 and B3 ports with the A2 and B2 ports blocked.

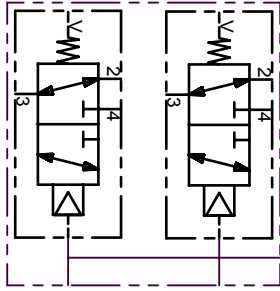