

6KProducts

Bringing reliability to high pressure hydraulic systems

DP0084

COMPACTOR OR HAMMER FLOW AND PRESSURE LIMITER

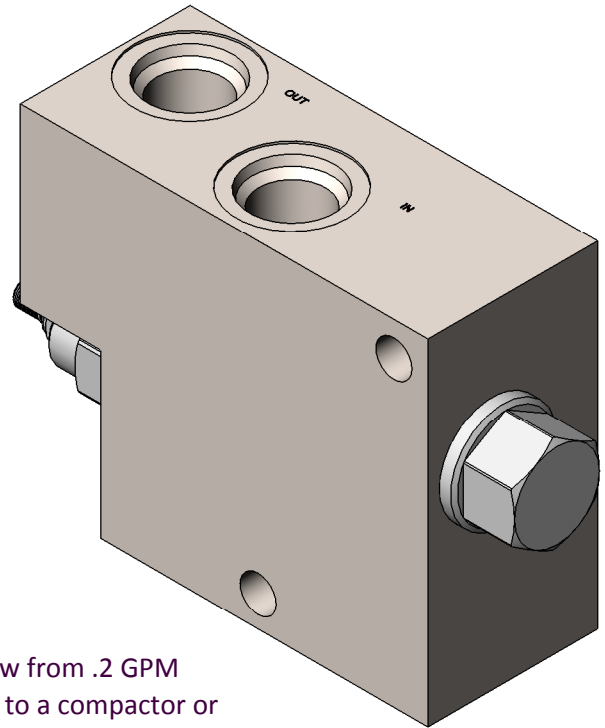
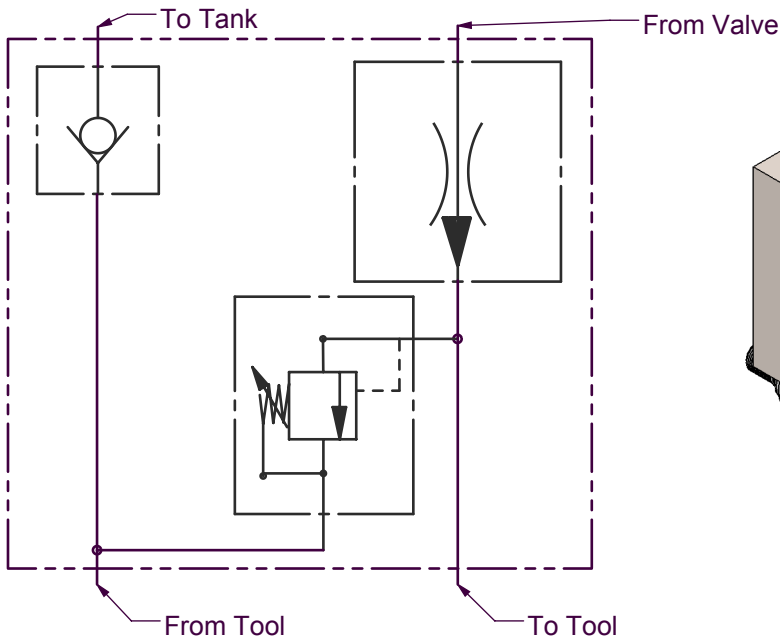

This assembly is designed to limit flow direction, limit tool flow from .2 GPM to 25 GPM and limit tool pressure between 200 and 3500 PSI to a compactor or hammer or other tool when used on a machine with a higher flow the tool is designed for. The flow is preset when ordered and is not wrench adjustable. The pressure is preset when ordered and can be field adjustable. For more information call 360-264-2141.

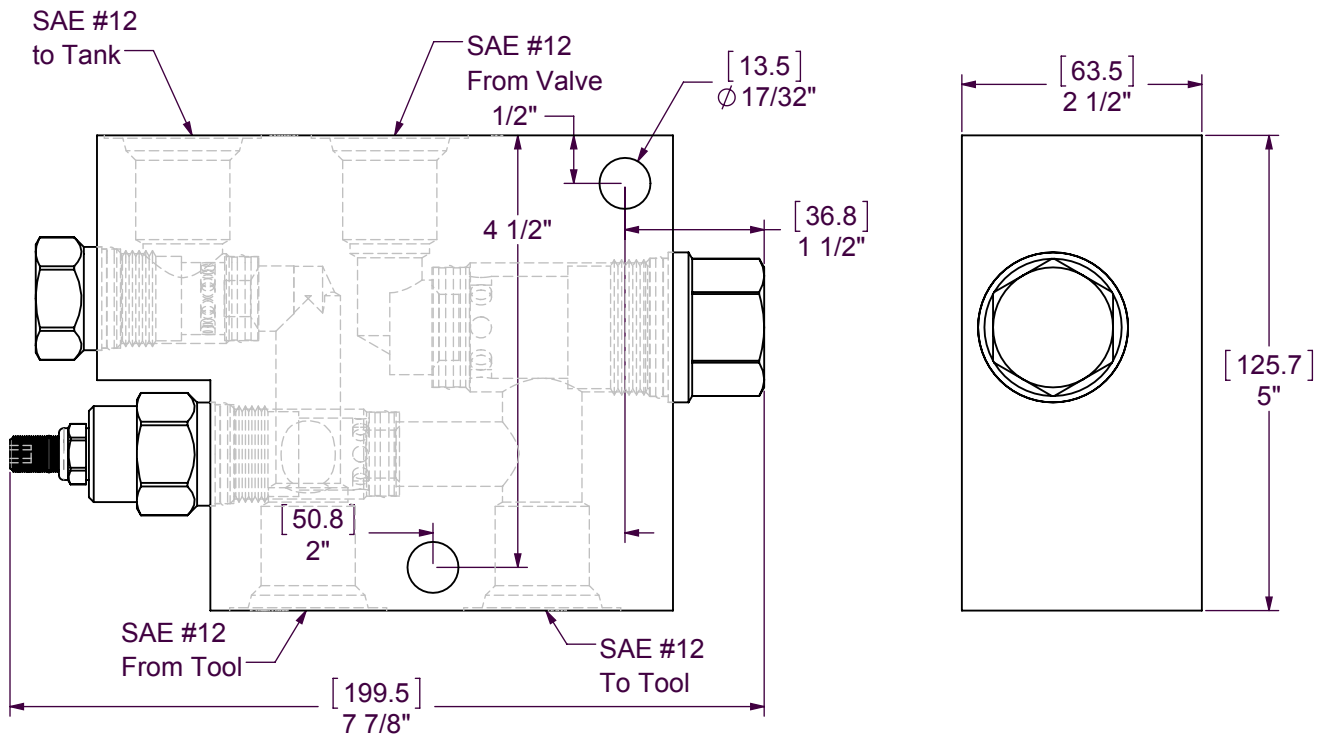

Specification subject to change without notice.